

Cruise report: Hydratech 2002
High resolution 2D and 3D seismic survey
in the Storegga area



Alesund, July 2002

Le suroit

NOUZE Hervé, CONTRUCCI Isabelle
FOUCHER Jean-Paul
THOMAS Yannick, MARSSET Bruno, NORMAND Alain, DIDAILLER Stéphane
REGNAULT Jean-Pierre, LE CONTE Sandie, THEREAU Estelle, DEAN Simon, GUIDARD
Stéphanie, LEKENS Wim , THROO Alexandre

TABLE OF CONTENT

.I. Overview	3
.I.1. Geological setting	4
.I.2. Survey locations.....	5
.I.3. Specific objectives	5
.II. Narratives of the cruise.....	6
.II.1. Dates.....	6
.II.2. Scientific party on board	6
.II.3. Schedule	7
.III. Navigation data.....	9
.IV. Multibeam echosounder data	9
.IV.1. Multibeam equipment description.....	9
.IV.2. Location map.....	10
.IV.3. Bathymetry: Preliminary map	11
.IV.4. Imagery: preliminary map	12
.V. Sediment profiler data (CHIRP).....	13
.V.1. Equipment Description.....	13
.V.2. Location map.....	14
.V.3. Chirp lines acquisition summary	15
.V.4. Examples of chirp profiles	19
.VI. 3D Seismic data.....	22
.VI.1. Instruments setup	22
.VI.2. Streamer information.....	22
.VI.3. Sources	23
.VI.4. 3D seismic configuration	24
.VI.5. Streamer configuration.....	25
.VI.6. Source configuration	26
.VI.7. Location Map	27
.VI.8. Navigation data processing	28
.VI.9. On board Seismic processing	29
.VI.10. 3D seismic data examples	30
.VII. 2D seismic data.....	33
.VII.1. Streamer configuration.....	34
1 Streamer balancing (P=plastic ring, B=bronze ring).....	34
1 Birds offsets (from streamer's head).....	34
.VII.2. Source configuration:	34
.VII.3. Location Map	35
.VII.4. Onboard processing.....	36
.VII.5. 2D seismic data example.....	36
.VIII. Overview about data quality.....	37
Acknowledgements :	37
Figure index :	39

ANNEXE

1 – On board processed 2D seismic lines 1 to 24.

The HYDRATECH cruise of the French research vessel Le Suroît was organized by Ifremer (Département Géosciences Marines, chief scientist: Hervé Nouzé, and Département Technologies Marines et Systèmes Informatiques, Service Acoustique et Sismique), in association with partners of the HYDRATECH and COSTA european programmes. We are grateful to Commandant Thierry Alix, the officers and the crew of the Le Suroît for their fruitful cooperation during this cruise.

I. Overview

High resolution 2D and 3D seismic surveys were carried out on the northern edge of the Storegga slides on the Norwegian continental slope during the HYDRATECH cruise of the French research vessel *Le Suroît*, from Alesund to Alesund, between 21 June and 20 July 2002. The cruise also included an EM300 swath bathymetry survey and several chirp sediment profiler records.

The study area extends from undisturbed sediments, upslope of the slides, to displaced sediments, in the axial part of the slides. It crosses slide scars and seafloor zones of potential present-day mechanical instability. It covers fields of pockmarks and various intra-sedimentary structures interpreted as gas escape structures.

Major objectives were to image in great detail the sediment deformation, the extent and properties of the Bottom Simulating Reflector (BSR), and the various gas escape structures. An ultimate goal of the surveys was to understand how gas hydrate dissociation, fluid flow and slope failure interplay in the study area.

The HYDRATECH cruise was tied up with several international programs. The 3D seismic survey area is a test site for the European program HYDRATECH, which aims at the development of techniques for the quantification of gas hydrates present in the marine sediments (coordinator: Prof. Graham Westbrook, the University of Birmingham). Within the HYDRATECH program, the 3D seismic survey carried out during the *Le Suroît* cruise was designed to provide a reference geometry of the sedimentary strata to place constraints on tomographic inversion of OBS records subsequently collected in the same area from the Norwegian research vessel *Jan Mayen*.

The Storegga slope is also a study site for the European program COSTA, which aims at a better assessment of continental slope stability (coordinator; Prof. Jurgen Mienert, Tromso University). The 2D seismic lines will be interpreted in association with partners of the COSTA project.

The HYDRATECH cruise was, as well, a site survey preparing scientific drilling in the early phase of the IPOD program (2003-2004). Locations of the drilling sites of the IODP drilling proposal (coordinator Prof. Karin Andreassen, Tromso University) will be revised to take into account the newly collected seismic data.

Thus, the HYDRATECH cruise was an important step in an international effort to understand slope failure and its related gas hydrate occurrences and fluid flow phenomena on the Storegga continental slope.

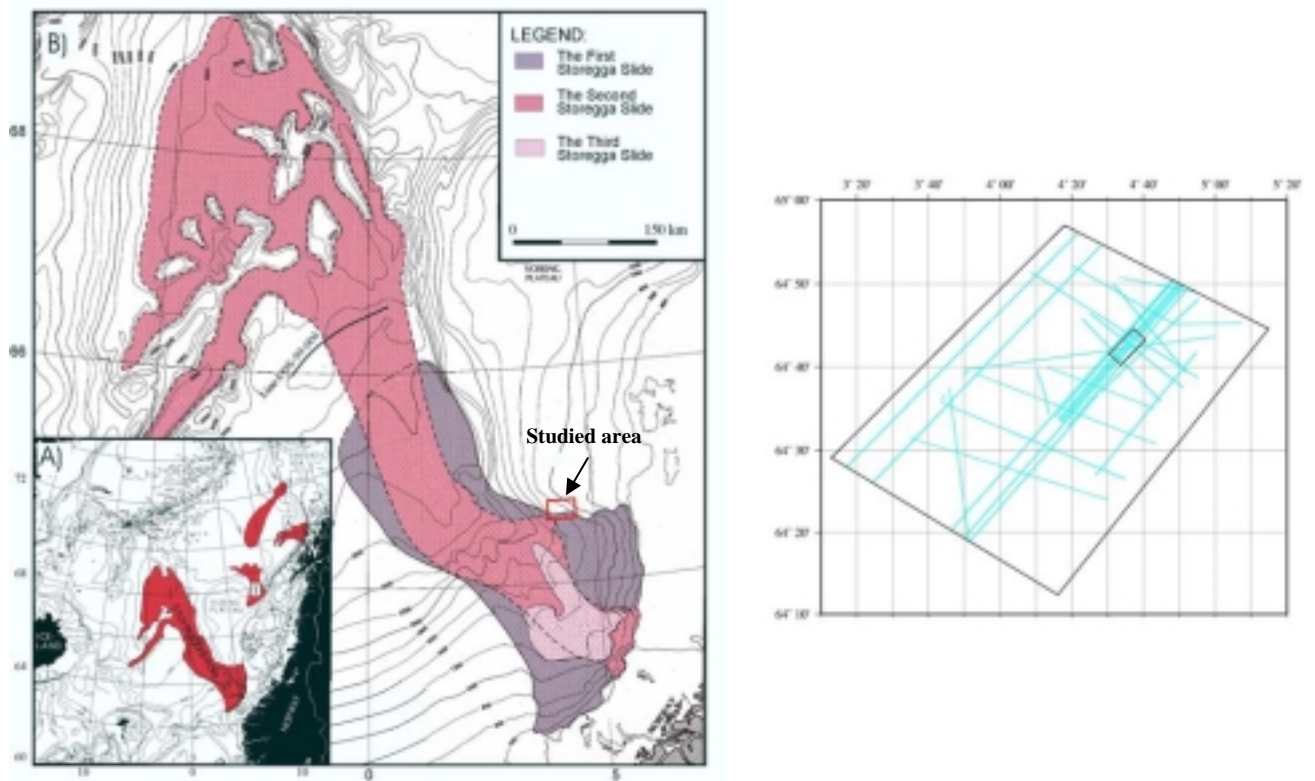

Figure 1 & Figure 2: general location map. Large box: multibeam survey. Small box: 3D seismic survey. Blue lines: 2D seismic lines.

.I.1. Geological setting

The Storegga slides, south of the Voring Plateau, on the Norwegian continental margin, are the largest submarine slide known on a continental slope. Displaced sediments extend over 800 km from the upper continental slope of the Storegga continental margin to the abyssal plain in the Norwegian basin (Figure 1). Three major slides have been identified that all would have occurred about 8 000 years ago. The mechanisms responsible for the failure of the sediments on the Storegga slope remain poorly known. Dissociation of gas hydrates, as a consequence of post-glacial ocean warming, could have played a major role as a triggering mechanism.

In the study area (3D survey), that is located upslope of the northern edge of the slide scar, the seafloor dips gently to the SSW. The shallow (<1km) sediment cover is rather uniform, with a fan-bedding mode of deposition (sediment strata keep nearly constant thickness or gradually thin out downslope). Evidence for the occurrence of gas hydrate is found in a sharp transition from weak to strong amplitudes of reflectors at the BSR at depth (about 360 ms td below seafloor). The strong amplitudes and reversed polarities the transition are interpreted to indicate the occurrence of free gas bound to the sediment strata. Gas hydrate is potentially present above the transition.

.I.2. Survey locations

Figures 1 and 2 show the area covered by the bathymetric survey, the locations of the 2D seismic lines and the area of the 3D seismic survey (" 3D box ").

The 3D box was centered on the geotechnical drilling site EDSO 6404/5-GB at N64°70.181' and E4°57.4633'. It was completed over an area of 7.7 km by 3.6 km, in a water depth of 1050-1125m, between:

A	N64°44.591'	E4°37.277'
B	N64°48.242'	E4°40.527'
C	N64°40.240'	E4°33.711'
D	N64°41.591'	E4°30.461'

.I.3. Specific objectives

The primary purpose of the survey was to gain insight into the 3D distribution of free gas and gas hydrate distribution with depth in the upper sediments (down to 500 m below the seafloor).

Specific objectives included:

- (1) to define the 3D detailed geometry of the sediment
- (2) to map BSR segments and determine their distribution and properties throughout the survey area,
- (3) to analyze the seismic transition, from weak reflectors above to enhanced reflectors underneath, at the base of the gas hydrate stability zone
- (4) to conduct detailed Vp compressional velocities analyses and relate anomalies to the occurrences of free gas and solid gas hydrate in the sediments (velocity analyses from 3D survey to be supplemented by those from 2D lines),

.II. Narratives of the cruise

.II.1. Dates

The cruise was divided into two legs:

Leg 1 : Alesund, June 21, 2002 – Alesund, July, 3 2002.

Leg 2: Alesund, July, 5 2002 – Alesund, July, 20 2002.

.II.2. Scientific party on board

The table below shows the list of the scientific staff who participated to the cruise on board N/O Le Suroit

NAME	NATIONALITY	SPECIALITY	LABORATORY	LEG	
				1	2
NOUZE Hervé	French	Geophysics	Ifremer – DRO/GM	x	x
FOUCHER Jean-Paul	French	Geophysics	Ifremer – DRO/GM	x	
MARSSET Bruno	French	Geophysics	Ifremer – TMSI/AS	x	
DIDAILLER Stéphane	French	Informatics	Ifremer – TMSI/AS	x	x
REGNAULT Jean-Pierre	French	Electronics.	Ifremer – TMSI/AS	x	x
THOMAS Yannick	French	Geophysics	Ifremer – TMSI/AS	x	x
NORMAND Alain	French	Bathymetry	Ifremer – DRO/GM		x
CONTRUCCI Isabelle	French	Geophysics.	Ifremer – DRO/GM	x	x
LE CONTE Sandie	French	Geophysics.	Ifremer – TMSI/AS	x	x
THEREAU Estelle	French	Data processing	Ifremer – DRO/GM	x	x
DEAN Simon	English	Geophysics	Southampton Oceanography C.	x	
GUIDARD Stéphanie	Belgium	Geophysics	Tromsø University (Norway)	x	
LEKENS Wim	Belgium	Geology	Bergen University (Norway)		x
THROO Alexandre	French	Geophysics	Institut Français du Pétrole	x	

.II.3. Schedule

The table below is a short description of the work conducted during the cruise

Day	Date	Position Long., Lat.	Main work All times are UTC times
1	21 June 2002		Arrival of the scientific party. Instruments set up on bord Le Suroit
2	22 June 2002		Departure (6h00) – 12h transit to 3D box working area 3D equipement at sea (18h30 – 22h30) – Equipement tests.
3	23 June 2002		Start of high resolution 3D data acquisition (2h37) 3D data acquisition: lines 1- 16
4	24 June 2002		3D data acquisition: lines 17 – 32 - Chirp data acquisition (6h-18h) Seismic vessel Ramform Vicking (PGS) shooting a 7500 i3 source and towing 8 x 8 km cables working in the survey area – Strong interference on the data
5	25 June 2002		3D data acquisition: lines 33 – 50 – Chirp data acquisition (6h-18h) Ramform Vicking still shooting – Strong wind 25 knots
6	26 June 2002		3D data acquisition: lines 51 - 65 – Chirp data acquisition (6h-18h) Ramform Vicking shooting
7	27 June 2002		3D data acquisition: lines 66 - 77 – Chirp data acquisition (6h-18h) Bad weather conditions : 3D acquisition stopped (16h38). Lines fuite 1 and fuite 2. Guns and streamers on board (22h). EM300 bathymetry acquisition (bad data quality)
8	28 June 2002		EM300 bathymetry acquisition. Guns and streamers at sea (12h30). 3D data acquisition: lines 78 - 85 – Chirp data acquisition (6h-18h)
9	29 June 2002		3D data acquisition: lines 86- 102 – Chirp data acquisition (6h-18h) Ramform Vicking shooting
10	30 June 2002		3D data acquisition: lines 103- 120 – Chirp data acquisition (6h-18h)
11	01 July 2002		3D data acquisition: lines 121- 137 – Chirp data acquisition (6h-18h)
12	02 July 2002		3D data acquisition: lines 138- 153 – Chirp data acquisition (6h-18h) End of data acquisition (22h47)
13	03 July 2002		– Equipement on board (0h15) – transit to Alesund Arrival in Alesund (16h).

14	04 July 2002		Port call in Alesund
15	05 July 2002		Departure from Alesund (15h) 12h transit to 3D box working area
16	06 July 2002		3D equipment at sea (5h00 – 6h00) 3D data acquisition: lines 154 - 163 – Chirp data acquisition (6h-18h)
17	07 July 2002		3D data acquisition: lines 163- 173 – Chirp data acquisition (6h-18h) End of 3D data acquisition (14h) Shift from 3D to 2D device configuration. 2D lines : H2D01.1
18	08 July 2002		2D lines: H2D01.2, H2D02.1 Stand by (Vicking crossing) H2D02.2, H2D02.3, H2D03.1, H2D04.1 Bathymetry and chirp (6h-18h)
19	09 July 2002		2D lines: H2D05.1, H2D06.1, H2D07.1, H2D08.1, H2D09.1 Bathymetry and chirp (6h-18h)
20	10 July 2002		2D lines: H2D10.1 Modification of the acquisition geometry (source shifted 1m on starboard side) H2D11.1, H2D12.1 Acquisition stopped at 13h20. Seismic on board. EM300 + chirp (6h-18h) only (Jan Mayen shooting).
21	11 July 2002		EM300 + chirp (6h-18h) only (Jan Mayen shooting). All work stopped at 18h40 : strong wind and sea. Stand By meteo
22	12 July 2002		3h48: start of bathymetry acquisition EM300 + chirp (6h-18h) only (Jan Mayen shooting)
23	13 July 2002		Seismic at sea, 2D configuration 8h35: start of 2D lines H2D13.1, H2D14.1, H2D15.1 Seismic vessel Falcon Explorer working in the area (8000cui...) Bathymetry and chirp (6h-18h) acquisition
24	14 July 2002		2D lines:H2D16.1, H2D17.1 EM300+chirp (6h-18h) 15h10: Seismic on board (Jan Mayen Shooting)
25	15 July 2002		Bathymetry + chirp (6h-18h).
26	16 July 2002		Bathymetry + chirp (6h-18h). 18h30 : seismic at sea, 2D configuration 19h56: start of 2D line H2D18.
27	17 July 2002		2D lines: H2D18.2, H2D19.1, H2D19.2, H2D20.1, H2D21.1 Bathymetry + chirp (6h-18h)
28	18 July 2002		2D lines: H2D21.2, H2D22.1, H2D23.1, H2D24

			15h55: end of seismic acquisition. Bathymetry + chirp only Bathymetry + chirp (6h-18h)
29	19 July 2002		Transit to Alesund. 15h: arrival in Alesund – End of Leg 2
30	20 July 2002		Departure of the scientific staff

.III. Navigation data

During the whole cruise, we used the Skyfix DGPS system to position the ship with a very good accuracy (positioning errors are expected to be about 1m). It was especially needed to have DGPS accuracy to compute precise source and receiver positions for the 3D seismic survey.

.IV. Multibeam echosounder data

Multibeam data acquisition was performed using the hull mounted echosounder of N/O Le Suroît. A full coverage map of the working area was acquired during the cruise. Water temperature measurements (SIPPICAN) were made on a regular time basis to provide information on the sea water sound velocity.

On the upper part of the survey area, we had some difficulties to correct the data using the temperature corrected water velocity only. Two water temperature measurements combined with salinity measurements (XCTD) were then conducted to solve these problems in this area.

.IV.1. Multibeam equipment description

EM 300 - Kongsberg Simrad (Norway)
Hull mounted plane and horizontal antennas
Depth range: 20-4000m
Frequency: 32 kHz
Number of beams: 135
Angular opening: 140°
Beam width: 1 x 2°

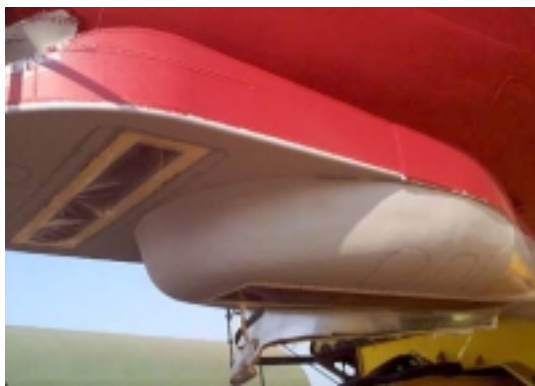

Figure 3: EM300 antennas on N/O Le Suroit

IV.2. Location map (Skyfix DGPS system)

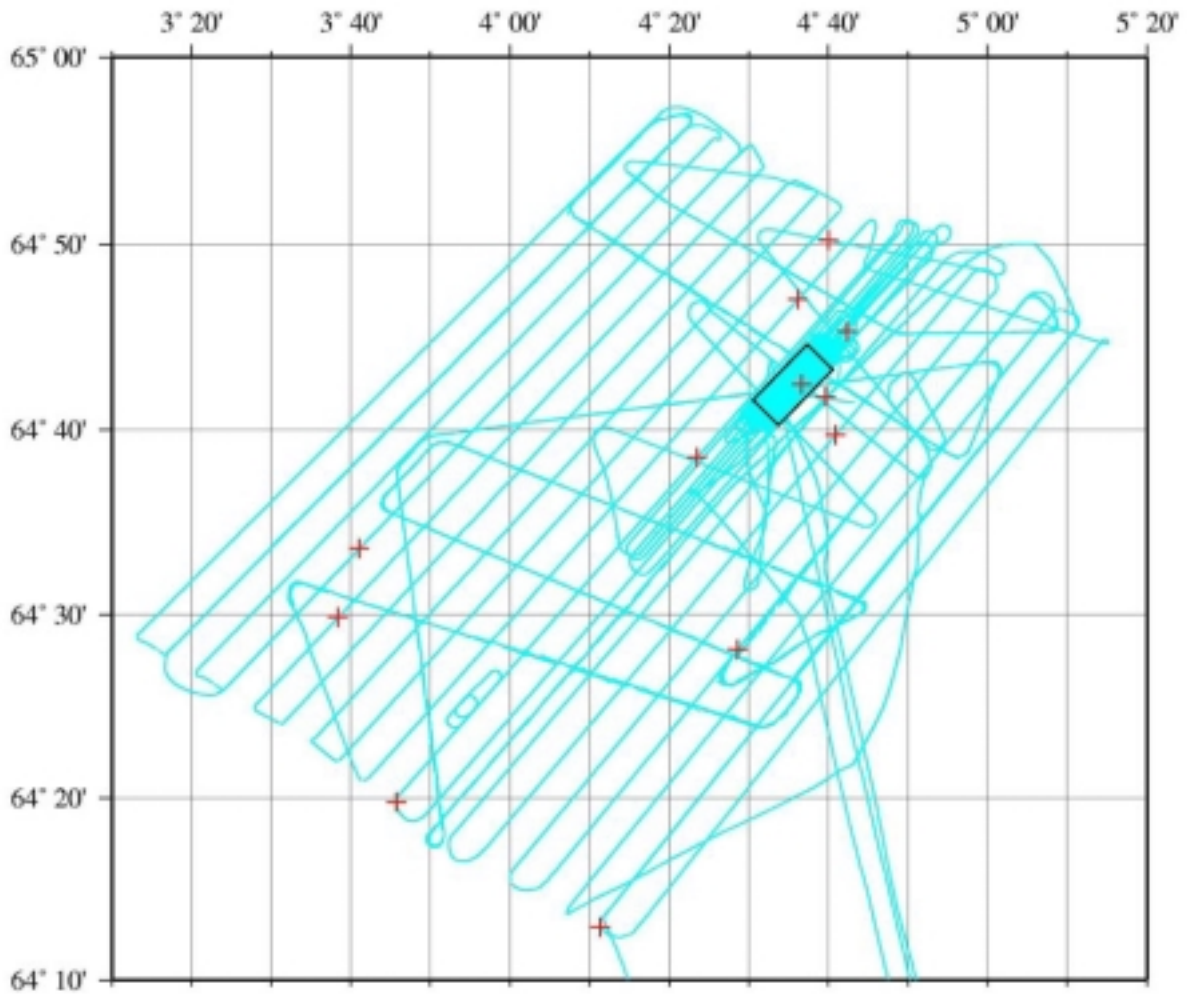

Figure 4: navigation map of the bathymetric survey. Blue line: navigation track. Red cross: sippican measurement

Bathymetry data was acquired along specific profiles at 8 knots, as well as during most of the 2D seismic lines, and during a few 3D lines, at 4.5 knots.

.IV.3. Bathymetry: Preliminary map

A preliminary processing of the data was done on board, in order to control the data quality as well as the full coverage of the area.

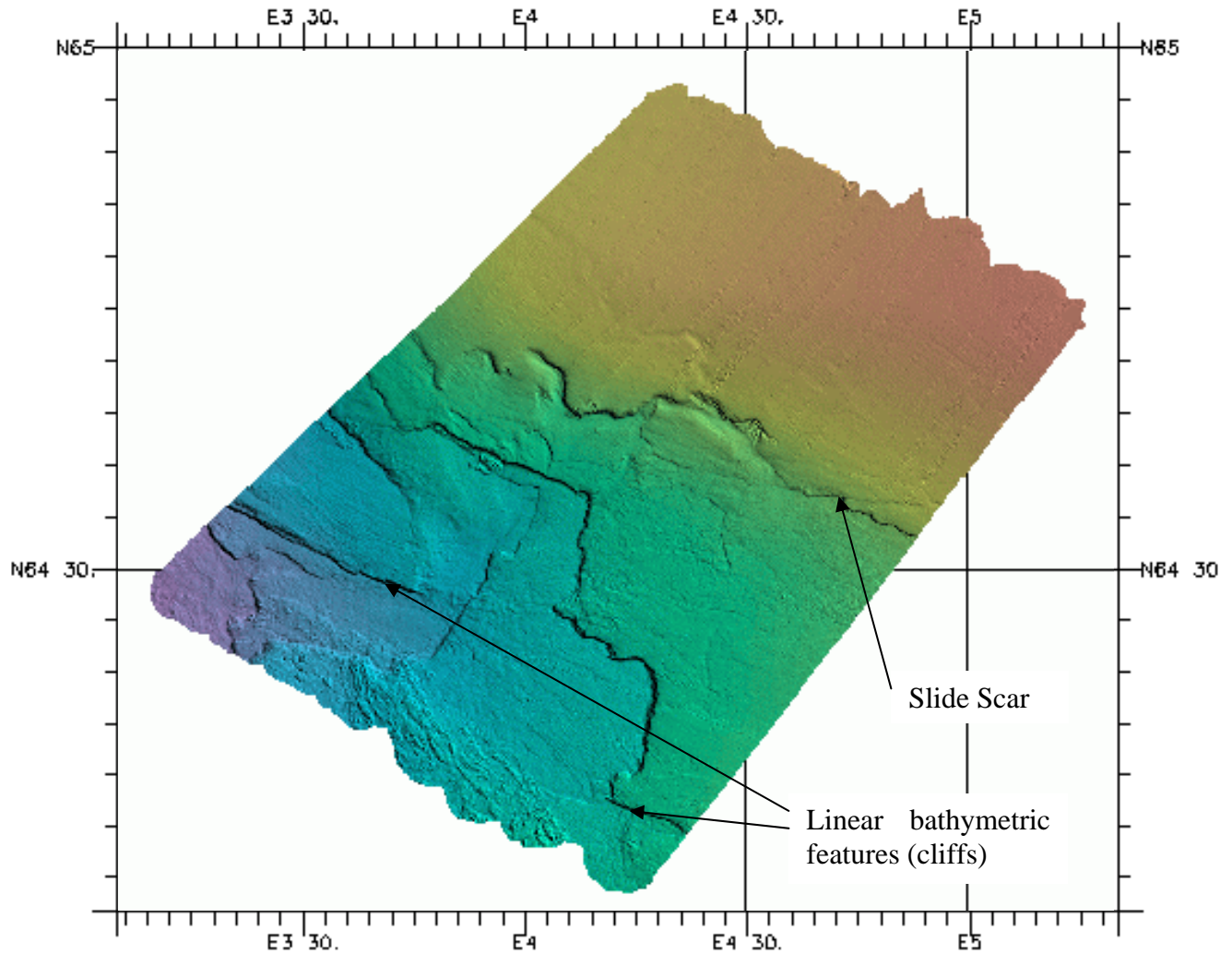

Figure 5: preliminary bathymetric map of the multibeam survey area. Note the slide scar feature, as well as the linear cliffs in the lower half of the map.

.IV.4. Imagery: preliminary map

On board processing included as well the computation of a reflectivity map of the survey area

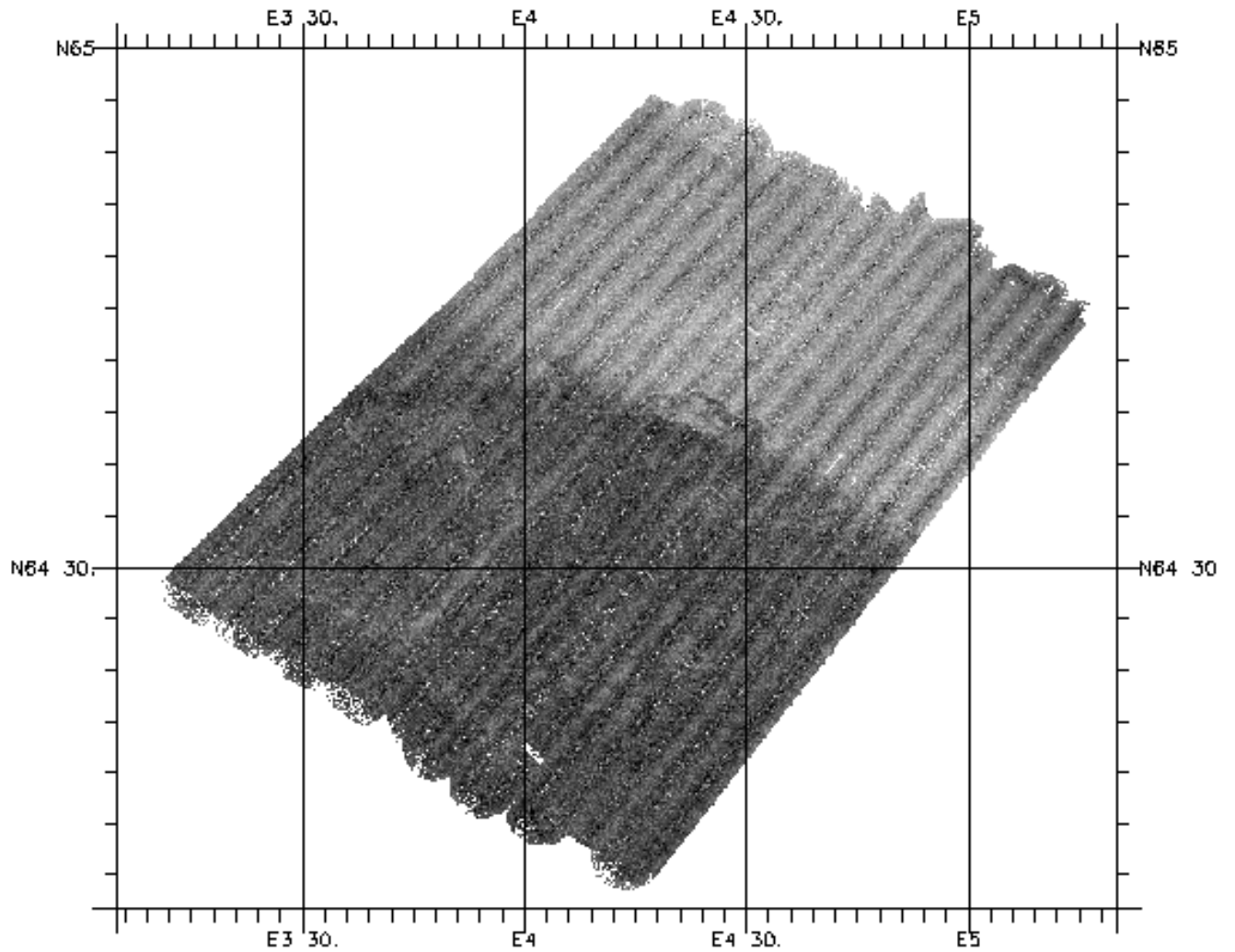

Figure 6: preliminary reflectivity map of the multibeam survey area

.V. Sediment profiler data (CHIRP)

During the whole cruise, and due to restrictions on the use of the CHIRP echosounder, the sediment profiler was used between 6h and 18h, in chirp mode (10 ms chirp) at 25% of the maximum power.

The data quality was good during the whole cruise, even in case of strong winds or sea. Average penetration is about 150-200 ms TWTT.

.V.1. Equipment Description

TRITON ELICS CHIRP sediments profiler
7 Hull mounted ERAMER Transceivers
Maximum acoustic level: 216 dB
Resonant frequencies: 2 & 5 kHz
Emission: ENERTEST 3kVA Amplifier
Veff max : 480 V
Reception: ORCA
Recording system: TEI
2 modes: 1/ Impulse mode 2kHz, 2/ CHIRP mode 2 to 5 kHz
Software: DELPH V2.0, acquisition board AU32 (16 bits sampling)



Figure 7: CHIRP Transceivers on R/V LE Suroit

.V.2. Location map
(Skyfix DGPS system)

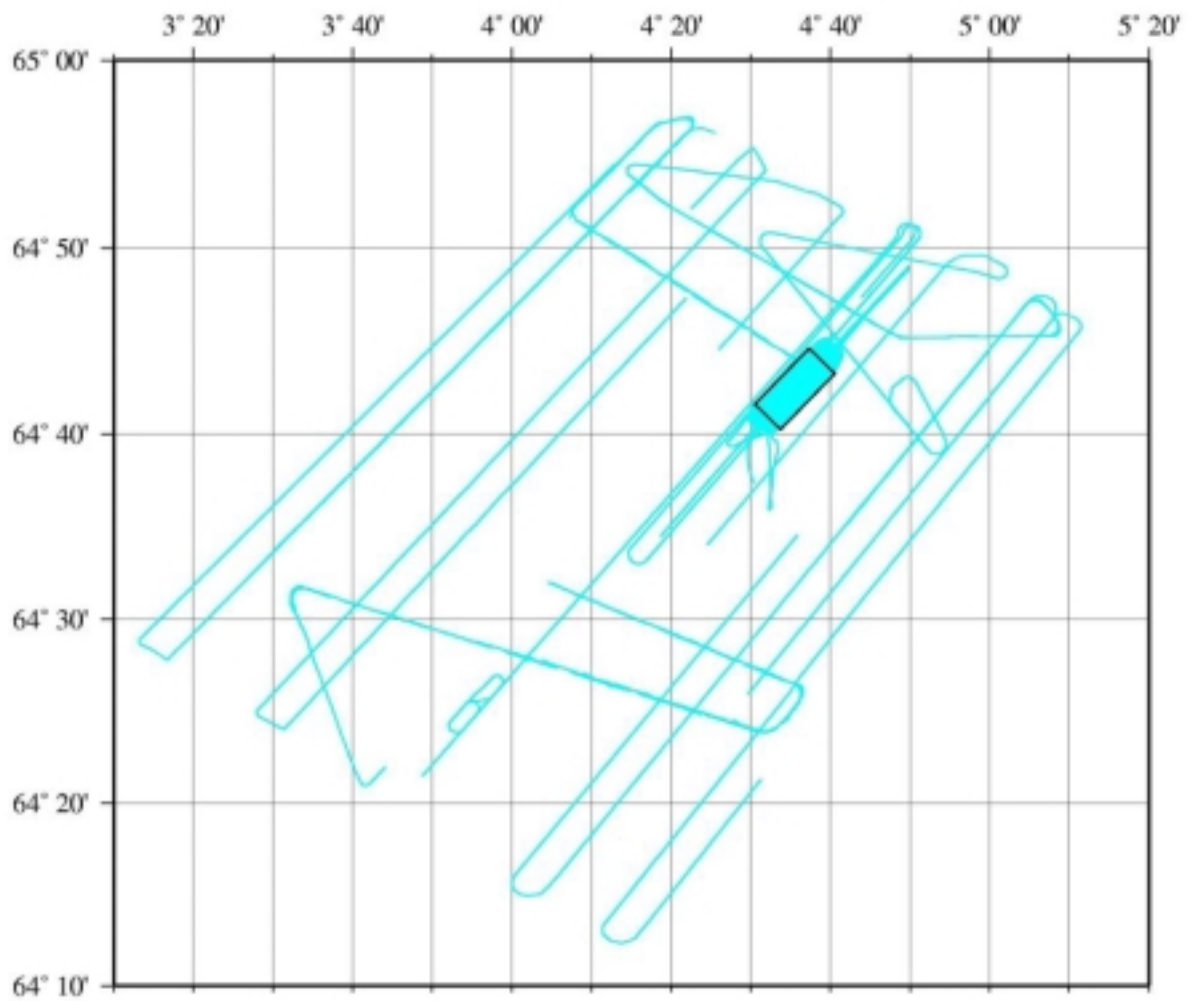

Figure 8: location map of the chirp lines

.V.3. Chirp lines acquisition summary

	Date	Begin hour	Ending hour
1	24/06/02	08h00	18h00
2	25/06/02	06h08	18h02
	25/06/02	06h06	12h01
3	26/06/02	?	?
4	28/06/02	06h03	12h23
5	28/06/02	12h24	17h57
6	29/06/02	06h02	09h55
	29/06/02	11h10	12h30
	29/06/02	12h43	17h15
7	29/06/02	17h21	18h14
	30/06/02	07h49	17h59
8	01/07/02	06h00	18h00
9	02/07/02	07h00	~08h20
	02/07/02	~08h21	12h52
	02/07/02	13h18	18h01
10	06/07/02	15h12	15h22
	06/07/02	15h34	17h58
11	07/07/02	06h18	17h59
12	08/07/02	06h10	09h30
	08/07/02	10h13	17h57
13	09/07/02	06h08	17h59
14	10/07/02	06h07	18h00
15	06/07/02	15h27	15h29
	11/07/02	06h08	17h58
16	12/07/02	06h06	17h59
17	13/07/02	06h05	17h55
18	14/07/02	06h04	15h47
	14/07/02	16h06	16h32
	14/07/02	16h58	17h58
19	15/07/02	06h06	14h56
20	15/07/02	15h02	17h59
21	16/07/02	06h06	17h59
22	17/07/02	06h05	17h58

Connections between CHIRP files and 3D lines

Profile CHIRP from 24/06/02 (6h -> 18h)

Profile CHIRP from 25/06/02 (6h -> 18h) au 26/06/02 (6h -> 12h)

Profile CHIRP from 26/06/02 (12h -> 18h) au 27/06/02 (6h -> 18h)

Profile CHIRP from 28/06/02 (6h40 -> 12h23)

Profile CHIRP from 28/06/02 (13h -> 18h)

Profile CHIRP from 29/06/02 (6h -> 17h15)

Profile CHIRP from 29/06/02 (17h15 -> 18h) au 30/06/02 (6h -> 18h)

Profile from 01/07/02 (6h -> 18h)

Profile from 02/07/02 (7h -> 18h)

Profile CHIRP from 06/07/02 (15h -> 18h)

Profile CHIRP from 07/07/02 (6h -> 18h)

Date	N° profile 3D	N° profile 3D	begin hour	end hour
24/06/02	21	11	06h09	07h04
	22	84	08h15	09h07
	23	12	09h35	10h36
	24	85	11h01	11h53
	25	13	12h23	13h27
	26	86	13h57	14h50
	27	14	15h10	16h16
	28	87	16h41	17h39
25/06/02	37	19	06h29	07h31
	38	97	07h53	08h50
	39	20	09h25	10h24
	40	92	10h51	11h48
	41	21	12h19	13h15
	42	93	13h44	14h40
	43	22	15h11	16h10
	44	94	16h30	17h25
	début 45	23	17h53	18h49
26/06/02	54	99	06h25	07h15
	55	28	07h45	08h45
	56	100	09h12	10h06
	57	29	10h37	11h36
	58	101	12h02	12h58
	59	30	14h05	15h06
	60	103	15h30	16h22
	61	31	16h52	17h54
27/06/02	fin 70	108	05h25	06h19
	71	36	06h49	07h48
	72	109	08h18	09h12
	73	37	09h38	10h35
	74	110	11h07	12h08
	75	38	12h35	13h33
	76	111	14h05	15h03

	77	39	15h39	16h38
28/06/02	78	112	13h04	13h55
	79	40	14h25	15h28
	80	113	15h53	16h44
	81	41	17h07	18h10
29/06/02	90	118	05h56	06h44
	91	46	07h18	08h16
	92	119	08h44	09h37
	93	47	10h10	11h08
	94	120	11h35	12h27
	95	48	13h00	13h59
	96	12	14h24	15h16
	97	49	15h42	16h42
	98	122	17h06	17h57
30/06/02	fin 107	54	05h35	06h37
	108	127	07h04	07h58
	109	55	08h26	09h28
	110	128	09h53	10h43
	111	56	11h14	12h10
	112	129	12h37	13h26
	113	57	13h53	14h56
	114	130	15h21	16h13
	115	58	16h39	17h41
01/07/02	125	63	06h23	07h27
	126	136	07h51	08h43
	127	64	09h05	10h09
	128	5 (infill)	10h40	11h27
	129	65	12h00	13h00
	130	111 *	13h26	14h15
	131	66	14h46	15h49
	132	110 *	16h12	17h02
	début 133	67	17h38	18h21
02/07/02	fin 142	18 (infill)	06h49	07h37
	143	69	08h05	09h06
	144	22 (infill)	09h35	10h30
	145	68	10h51	11h49
	146	1 (infill)	12h14	13h03
	147	96 (infill)	13h37	14h38
	148	26 (infill)	15h05	15h54
	149	136 (infill)	16h21	17h23
06/07/02	157	112 *	14h50	15h49
	158	27 *	16h18	17h08
	début 159	109 *	17h37	18h36
07/07/02	168	54 (infill)	06h01	06h52
	169	8 (infill)	07h28	08h24
	170	85 (infill)	08h51	09h40
	171	23 *	10h08	11h08

	172	81 (infill)	11h36	12h27
	173	14 (infill)	12h54	13h50

.V.4. Examples of chirp profiles

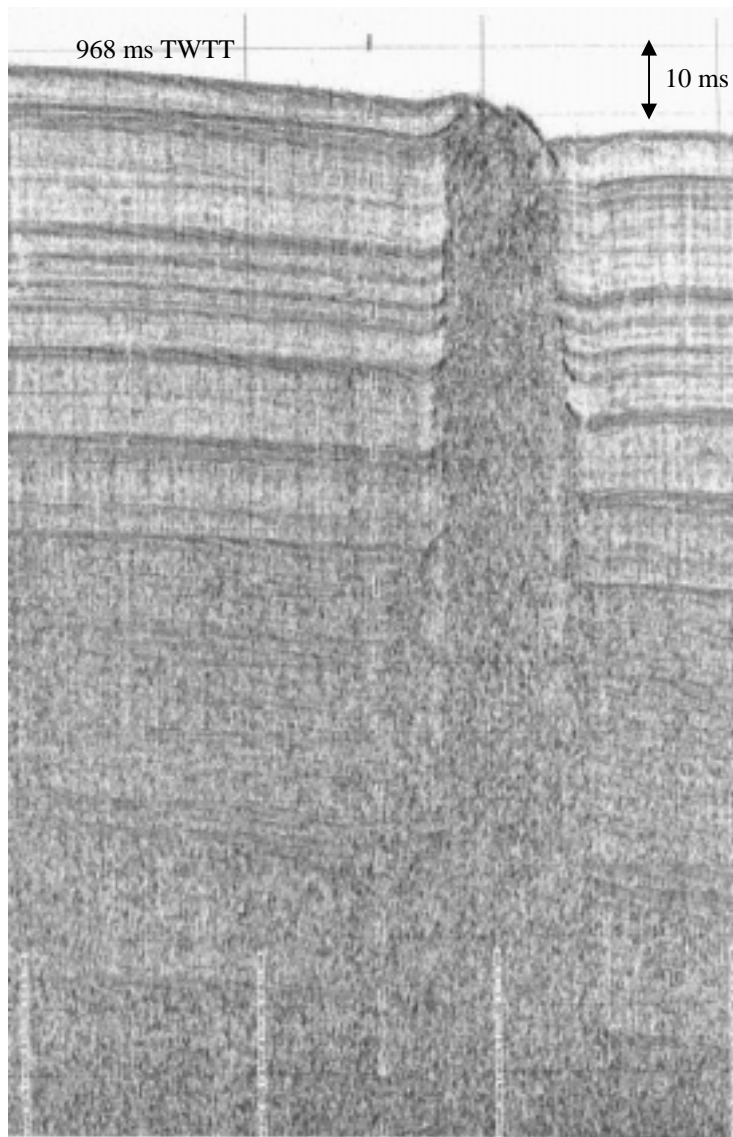

Figure 9: Chirp record, 14 July 2002, 10h04-10h14

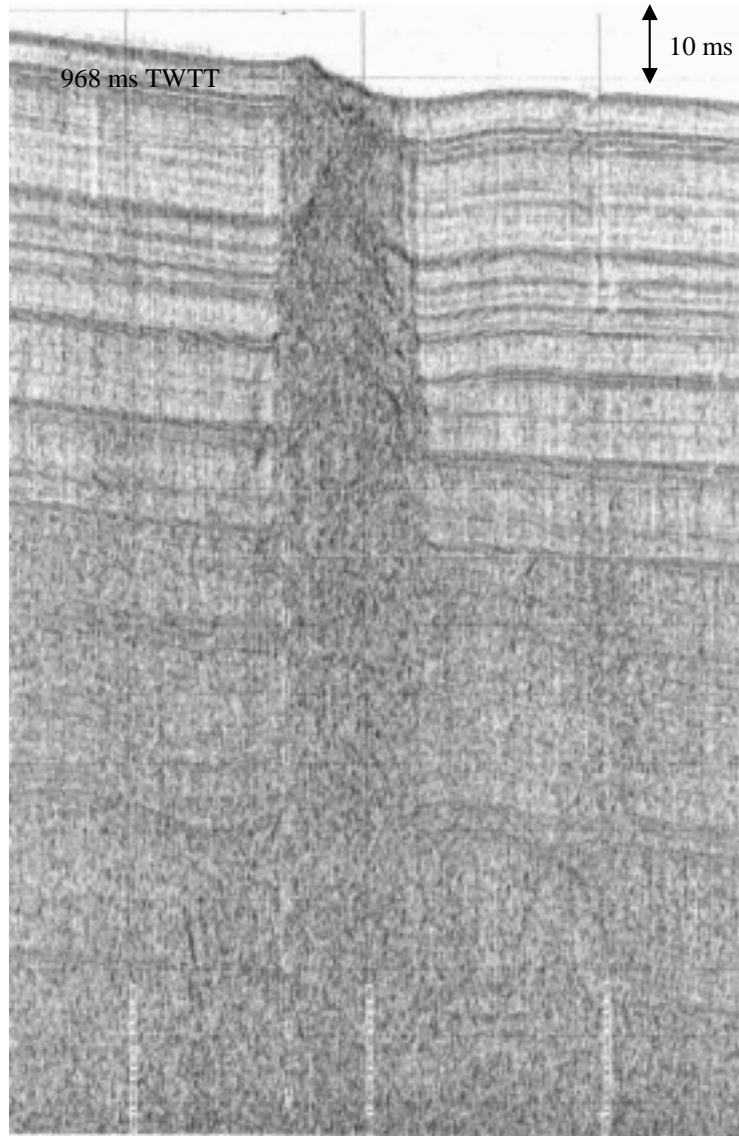

Figure 10:Chirp record, 14 July 2002, 9h58-10h04

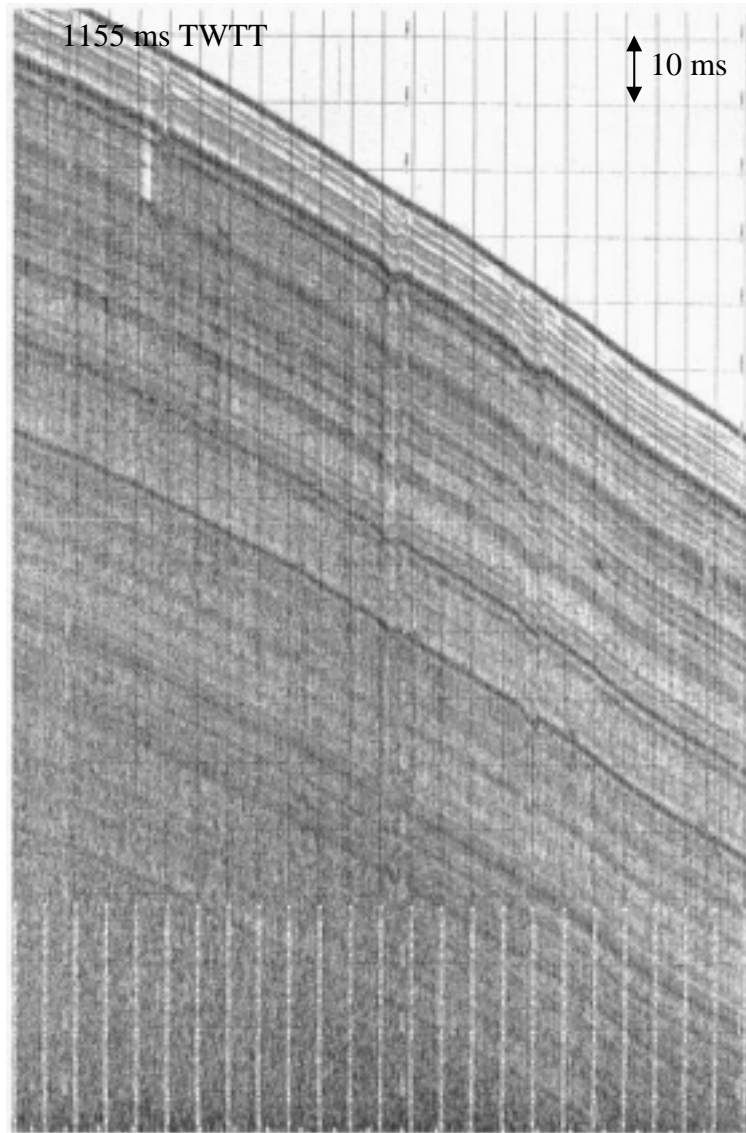

Figure 11:Chirp record, 27 June 2002, 9h12-9h57

.VI. 3D Seismic data

Seismic data was acquired using Ifremer's new high resolution seismic acquisition system. This system was developed in the framework of the "HR 3D" project (Ifremer).

.VI.1. Instruments setup

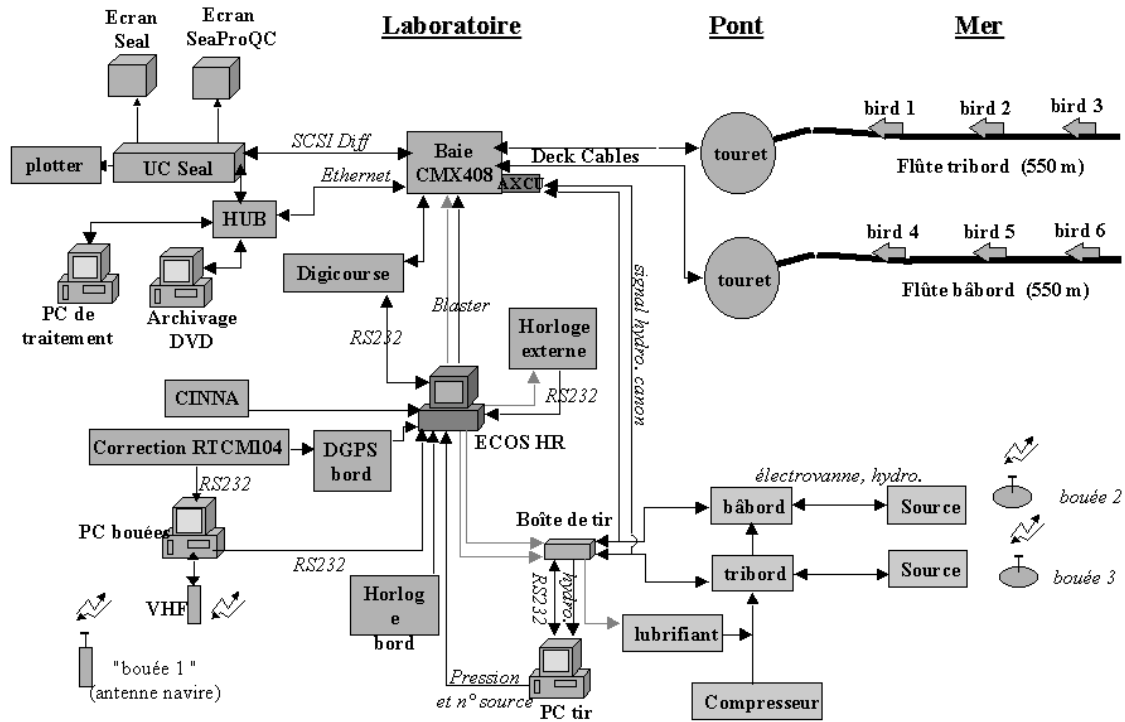

Figure 12: synopsis of the seismic acquisition system on board N/O Le Suroit, showing the connections between the different elements of the HR system.

.VI.2. Streamer information

Individual elements information

The streamers are composed of different individual elements. These elements are assembled to compose the 2D or 3D streamers.

SHS (Short Head Section): 65 m ("Jésus" 15 m from head), ∴ 50 double ∴ 70
 water break: 2 hydrophones (61.3 et 61.6 m from head)
 Tail collar: 15 m from head

RUM (Repeater Unit Module): – 40 cm

ES HR "head" (Elastic Section) and "tail" (Tail Elastic Section) :

49.8 m long, ∴ 50
 Acoustic coil: 2.5 m from head
 Bird coil: 47.3 m from head

ALS (Active Line Section): 24 channels x 6.25 m (8 hydrophones, 0.78 m spacing)
149.8 m long, ∴ 50, 12 FDU2
Acoustic coil: 9.2 m from head
Bird coil: 140.5 m from head
First channel center: 3 m from head (first hydro.: 0.4 m from head)

Tail Nylon string: 100 m

Recording unit: SEAL (Sercel)

.VI.3. Sources

In order to produce a signal with a high frequency content and a good primary to bubble ratio, the seismic source was composed of one (3D) or two (2D) Mini-GI guns (Sodera), with a 24i³ Generator chamber volume and a 24i³ Injector chamber volume operated at 140 bars.

Gun delay was recorded on auxiliary traces using Time Break hydrophones placed on the guns (delay was very stable with a value of about 20 ms during the cruise).

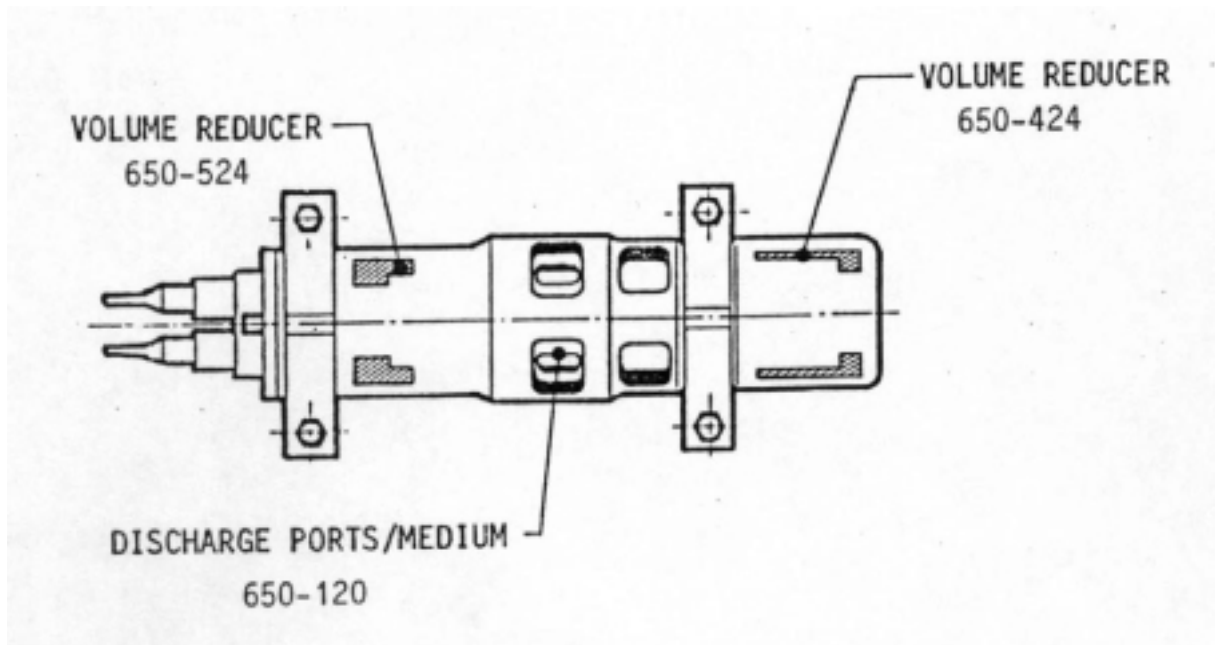

Figure 13: Mini G-I GUN

The gun is composed of two separate chambers (Generator and Injector). The opening of the generator chamber generates the seismic signal. The injector chamber is used to reduce the secondary bubble pulses. Thus it is possible to obtain a clean signal with a single gun.

.VI.4. 3D seismic configuration

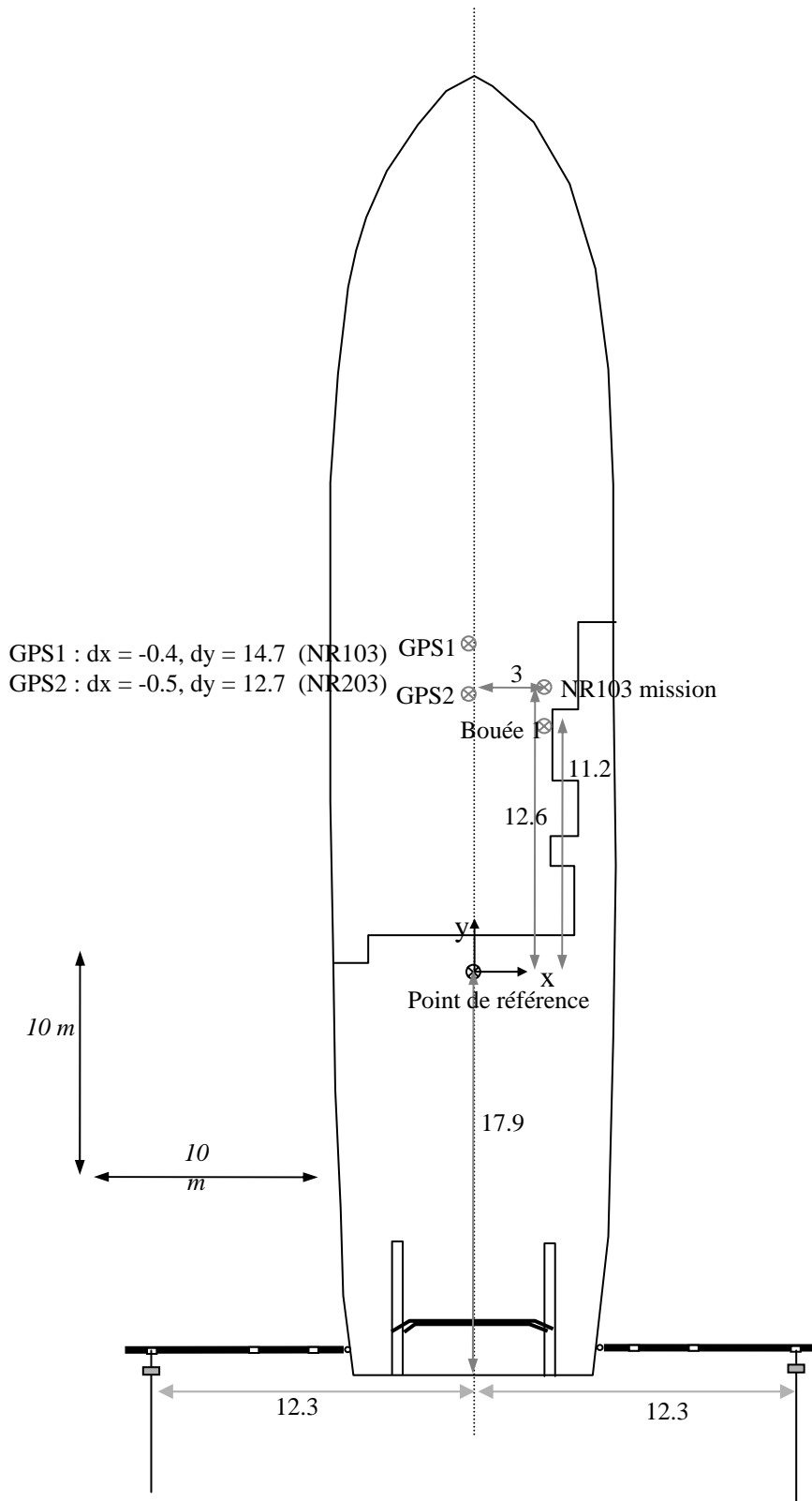

Figure 14: positions of the GPS antennas and streamers heads relative to the ship's reference point – 3D acquisition configuration

.VI.5. Streamer configuration

2 streamers:

- Starboard streamer: SHS + RUM + ES + ALS + ALS + ES + Tail nylon string
- Port streamer: SHS + RUM + ES + ALS + ALS + ES + Tail nylon string
- Total length: 515 m
- Active length: 300 m
- Streamer depth 3m (as unfavourable sea conditions were expected, in order to avoid too much noise on the streamer, the streamer immersion was set to 3m).
- Number of bird units : 3 for each streamer

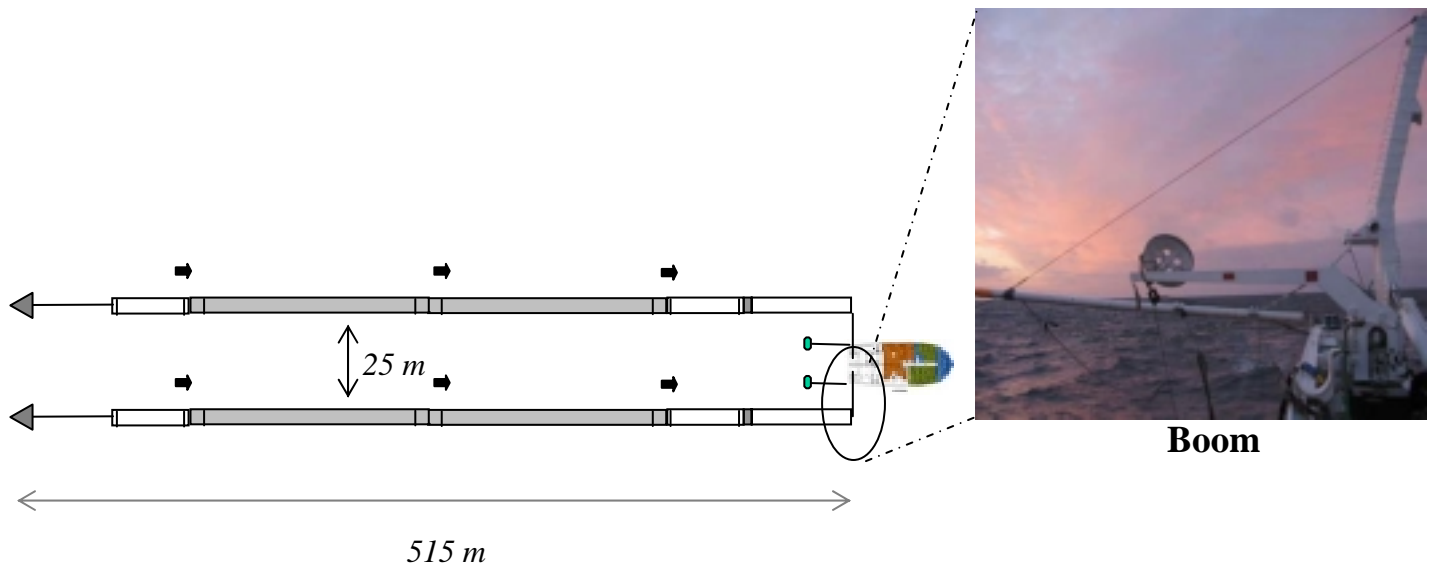

Figure 15: 3D acquisition geometry

Streamer balancing (P=plastic ring, B=bronze ring)

Reference salinity: 34.59 psu

Reference temperature: 10.6°C

Balancing is obtained by adding a number of weights (bronze rings) on the streamer.

Cruise configuration: ALS: PPP B PPPP B PPPP B PPPP B PPPP
ES: B B

Birds offsets (from streamer's head)

Bird 1: 97.7m

Bird 2: 259.4m

Bird 3: 402.3m



Figure 16 : Bird unit



Figure 17 : Starboard streamer

.VI.6. Source configuration

For the 3D acquisition, we used 2 lines including 3 mini-GI guns each. From the tests that were conducted it appeared that the penetration obtained with one gun was sufficient to reach our objectives. Thus only one of the guns was operated on each line, in flip-flop mode (see below). The other guns were used as spare guns in case of failure. Shooting interval was set to 3 s (about 6.25 m at 4.5 knots).

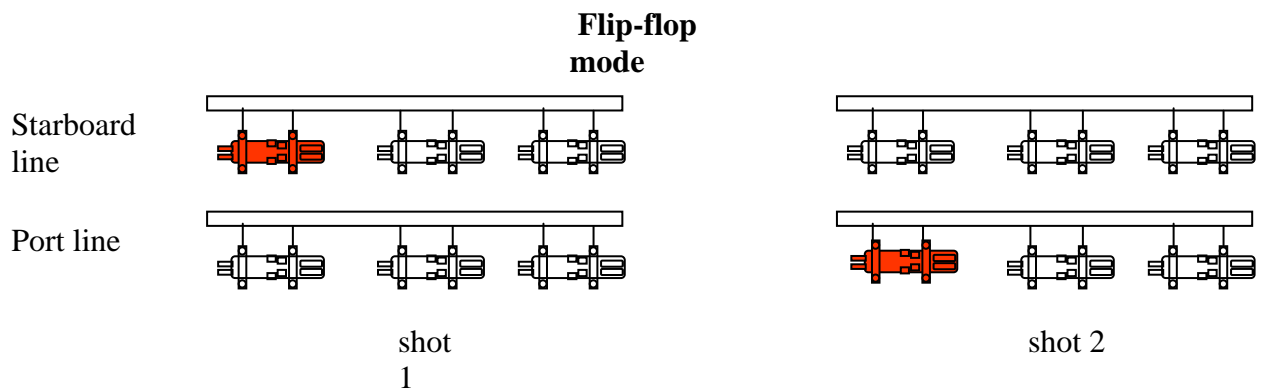

Figure 18:3D source configuration

Recording settings:

Recording format SEGD revision 2

Sampling frequency: 1000 Hz

Recording length: 2000 ms

Recording delay 1000 ms

Aux 1 = TB gun 1, Aux 2 = TB gun 2, Aux 3 = Water break starboard side streamer, Aux 4 = Water break port side streamer

Navigation buoys:

Buoy 1 = Ship

Buoy 2 = starboard side source line

Buoy 3 = port side source line

.VI.7. Location Map

(Skyfix DGPS system)

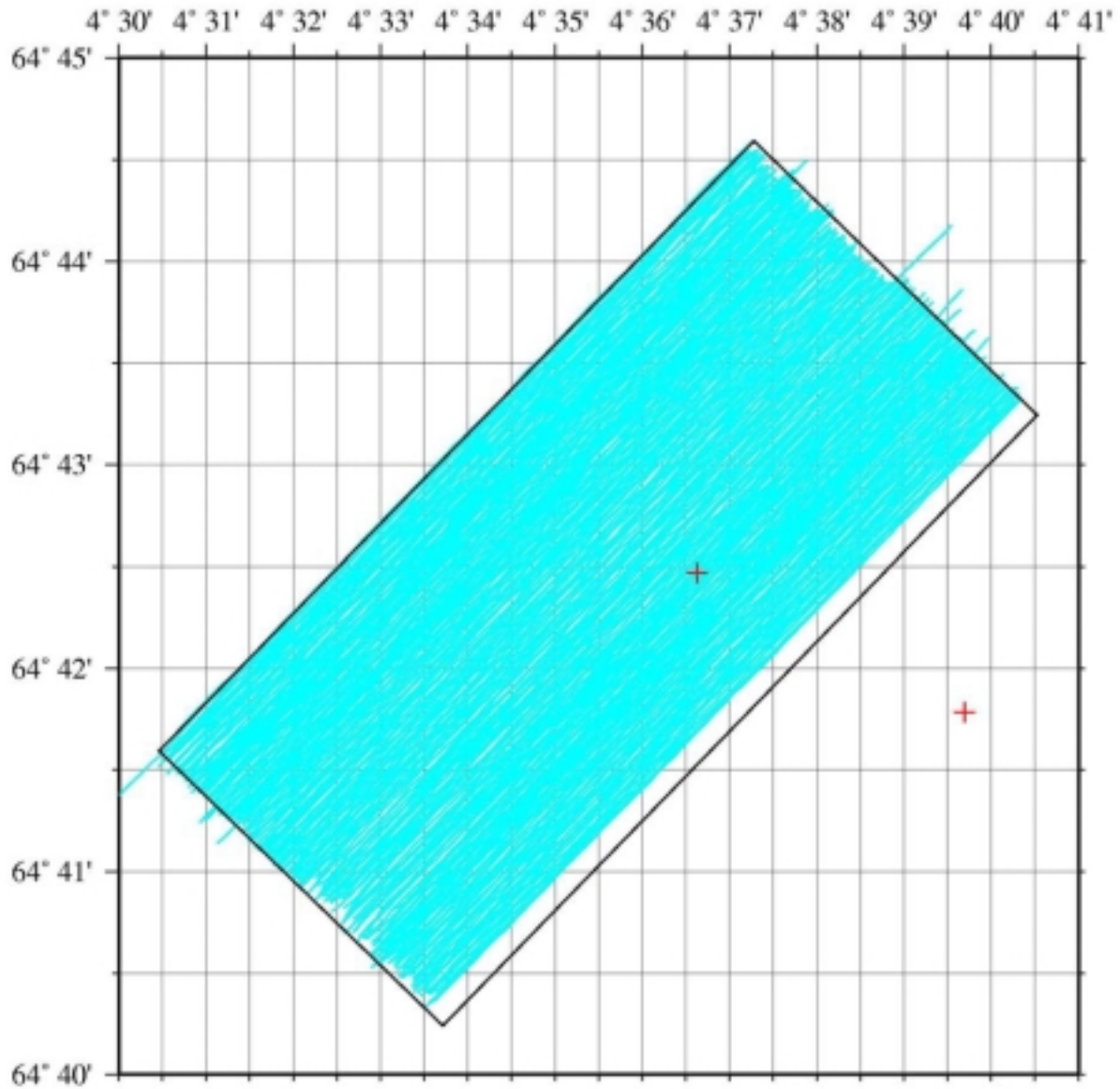

Figure 19: 3D lines location map (acquisition speed 4.5 knots).

.VI.8. Navigation data processing

One of the key points of a 3D seismic acquisition is the navigation processing. This processing has to be done in real time in order to be able to modify the acquisition plans according to the 3D survey area fold map.

Navigation processing includes:

- Navigation times control
- Positioning data (ship and buoys) edition and filtering
- Birds parameters (immersion and heading) edition and filtering
- Calculation of source and receivers positions using device geometry, positioning data and ship and birds headings.

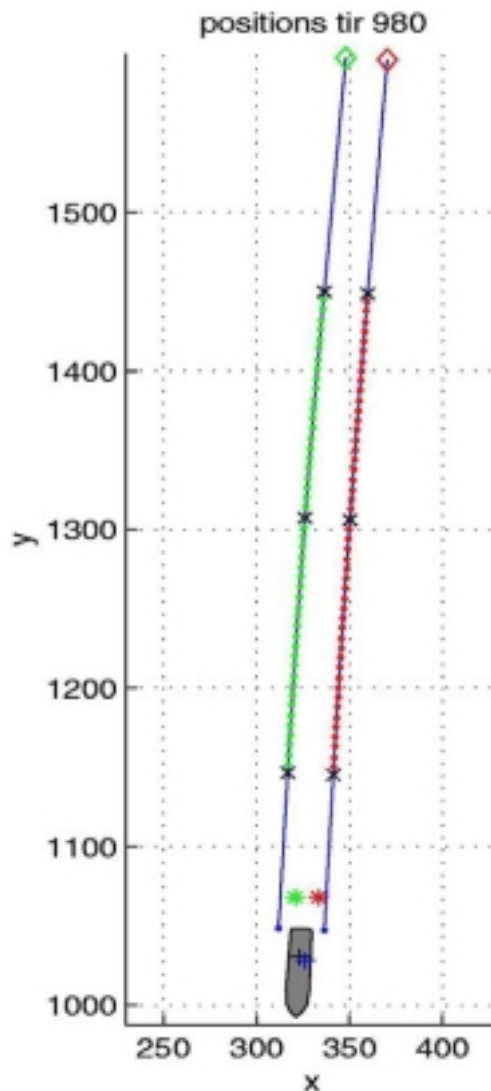

Figure 20: Example of the source and receivers positions calculated for a single shot

- Fold map computation : Mid-point positions are computed using source and receiver positions. With a 6.25x6.25m bin size and taking into account the acquisition parameters, the theoretical fold is 12.

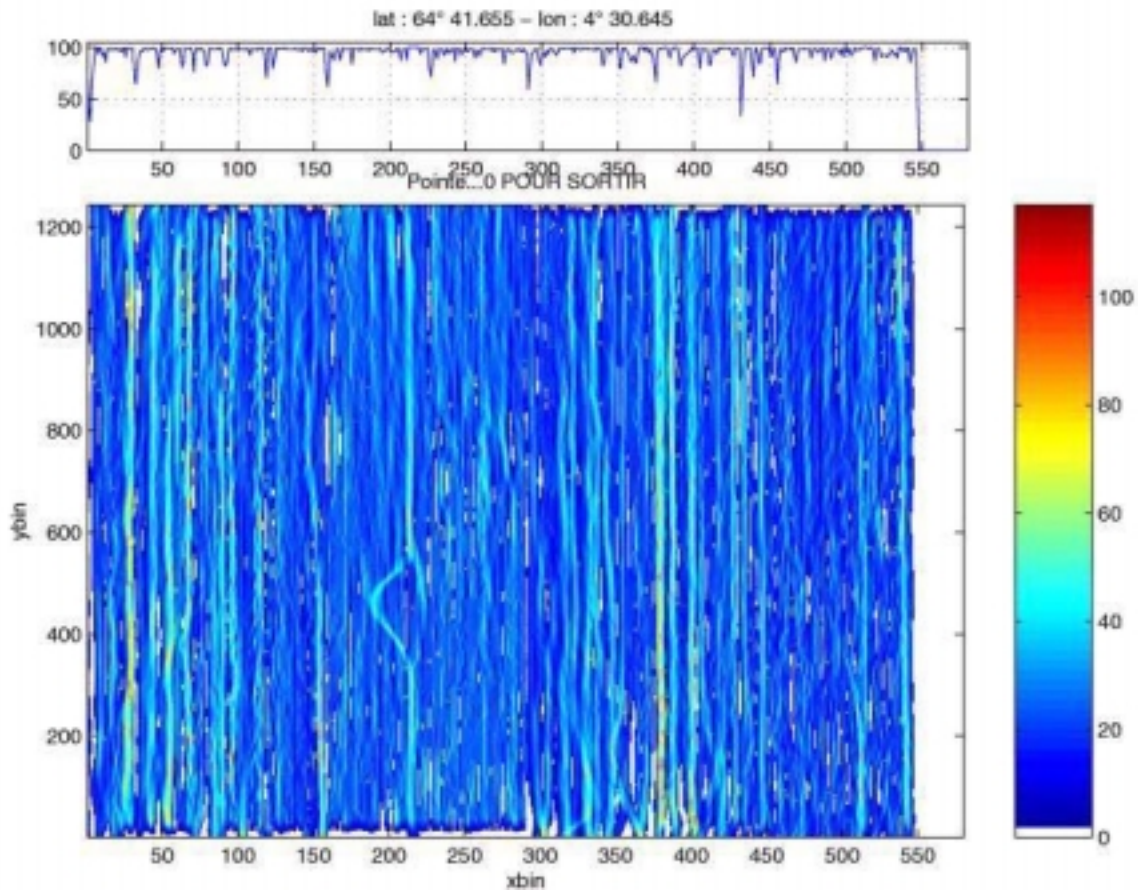

Figure 21: Final fold map with a 6.25x6.25m bin size

.VI.9. On board Seismic processing

A basic processing was conducted on board to control the data quality. Processing included:

- Channel decimation (1 channel out of 2)
- SEGD to SEG-Y conversion
- Data band-pass filtering (20-25-200-250Hz)
- Data windowing (1000-2200ms)
- Gun delay correction (20ms)
- Shot and receiver geometry
- Binning
- Band-pass filtering
- Constant velocity stack

.VI.10. 3D seismic data examples

Shot data:

The figure below shows 3D data for a single shot:

a/ raw data

b/ band pass filtered data

c/ frequency spectrum

note the hole in the frequency spectrum due to the streamer immersion (3m)

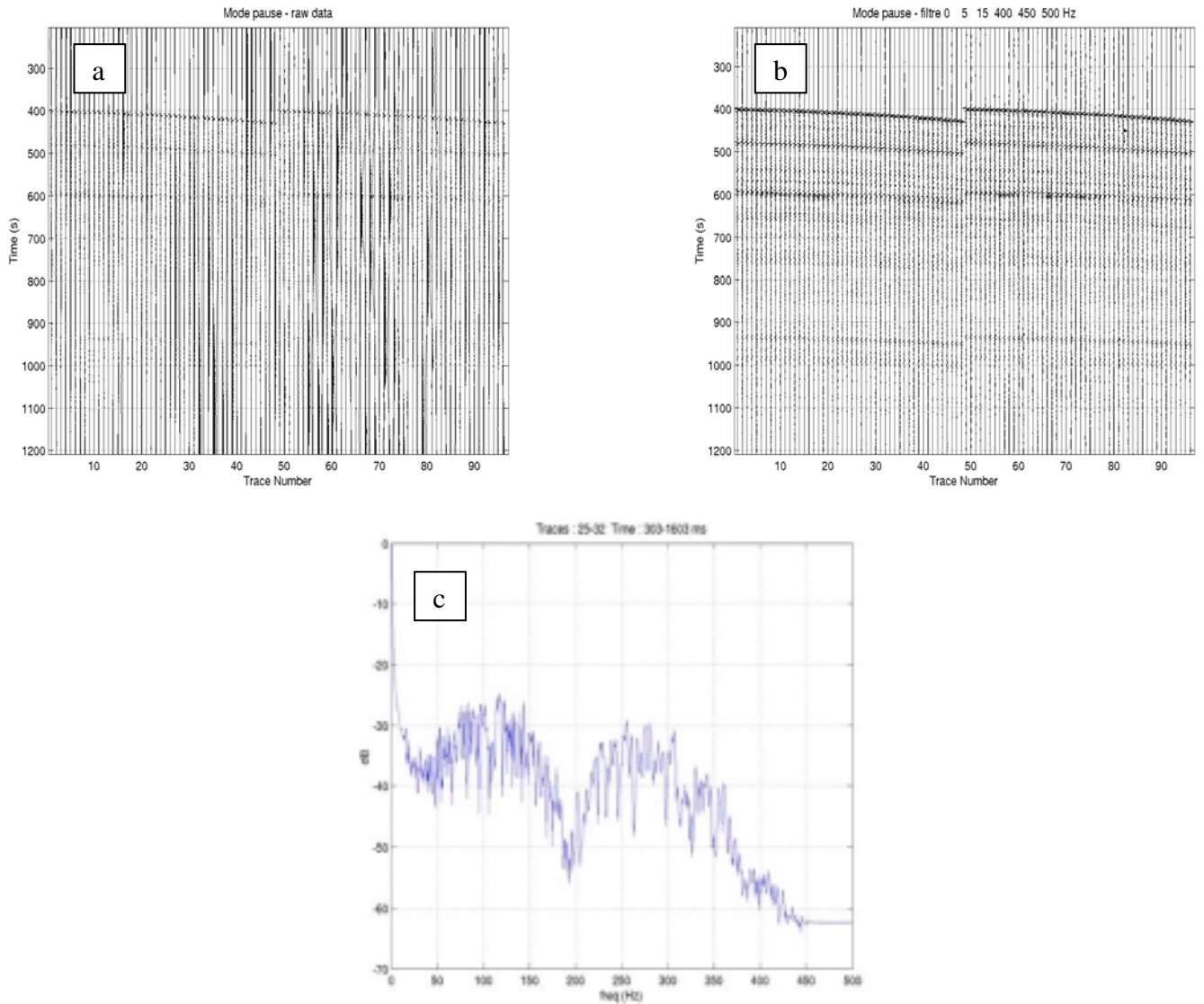

Figure 22: 3D shot data

/home2/cyrnea/htk2002/data/stack59wb.seg - Bin X n° 121

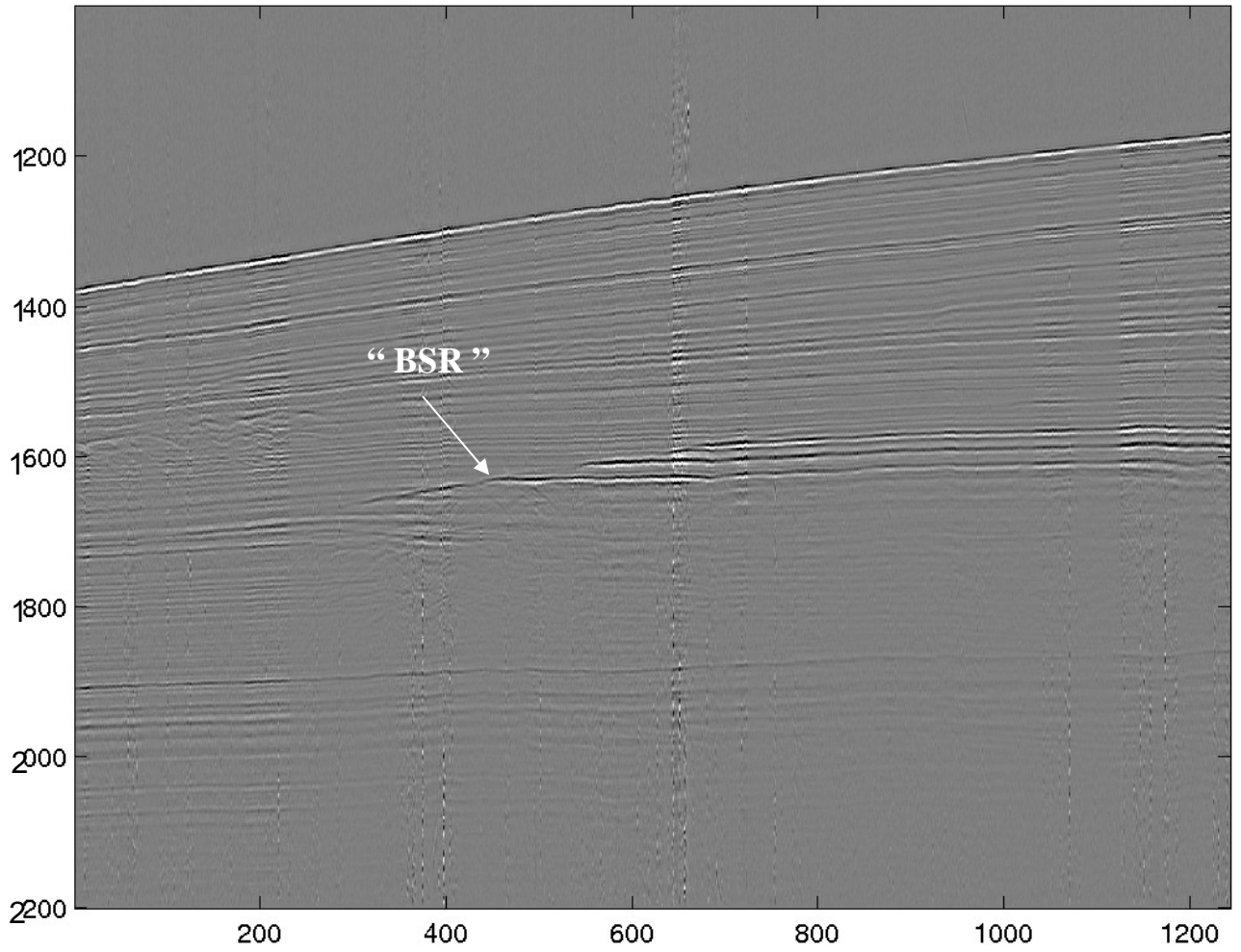

Figure 23:3D cube stacked data: inline line 121

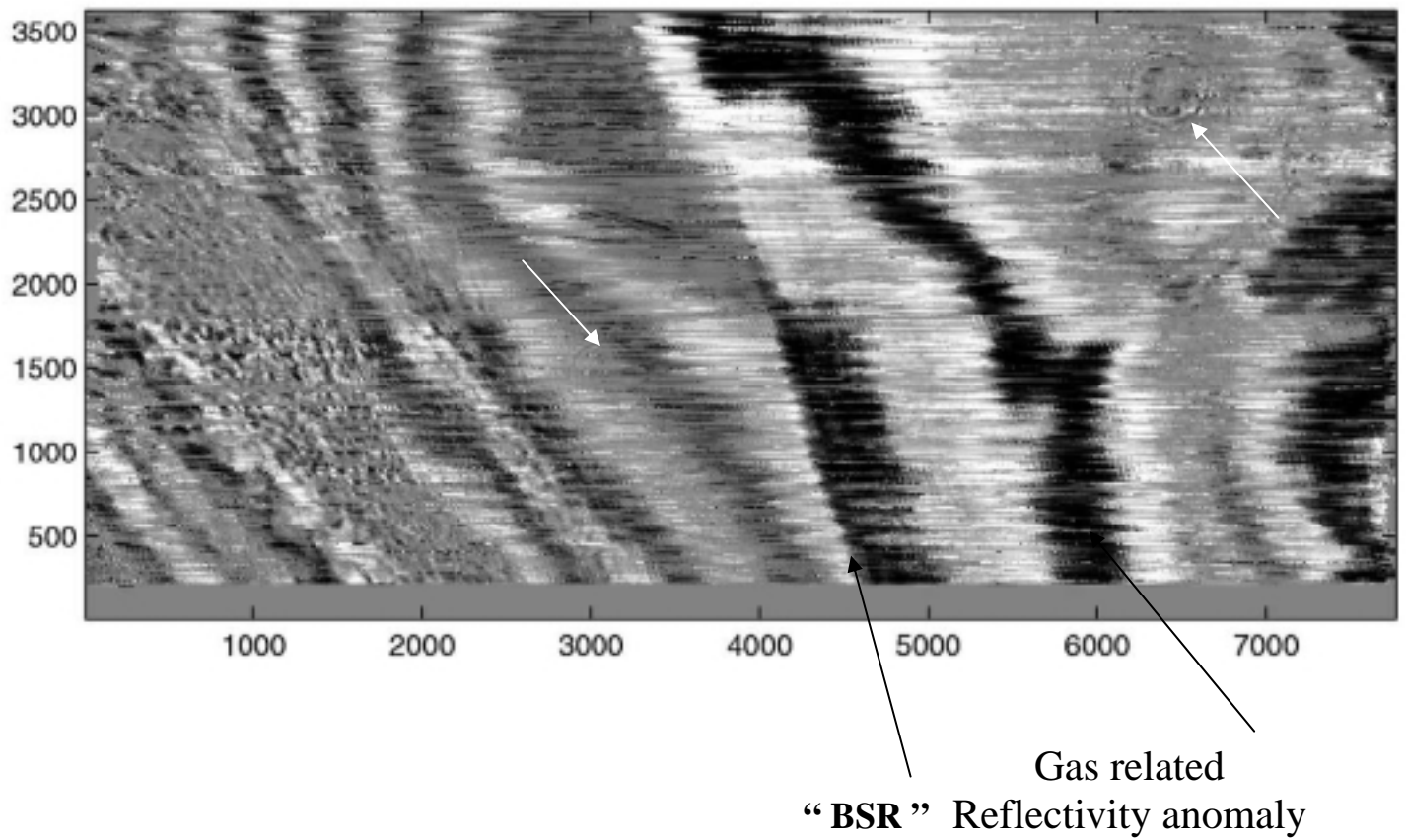

Figure 24: Time slice of the 3D seismic box (1600ms). Note 1/ the “BSR” reflection crossing sedimentary reflections, 2/ the rounded structures (white arrows) probably related to fluid escapes.

.VII. 2D seismic data

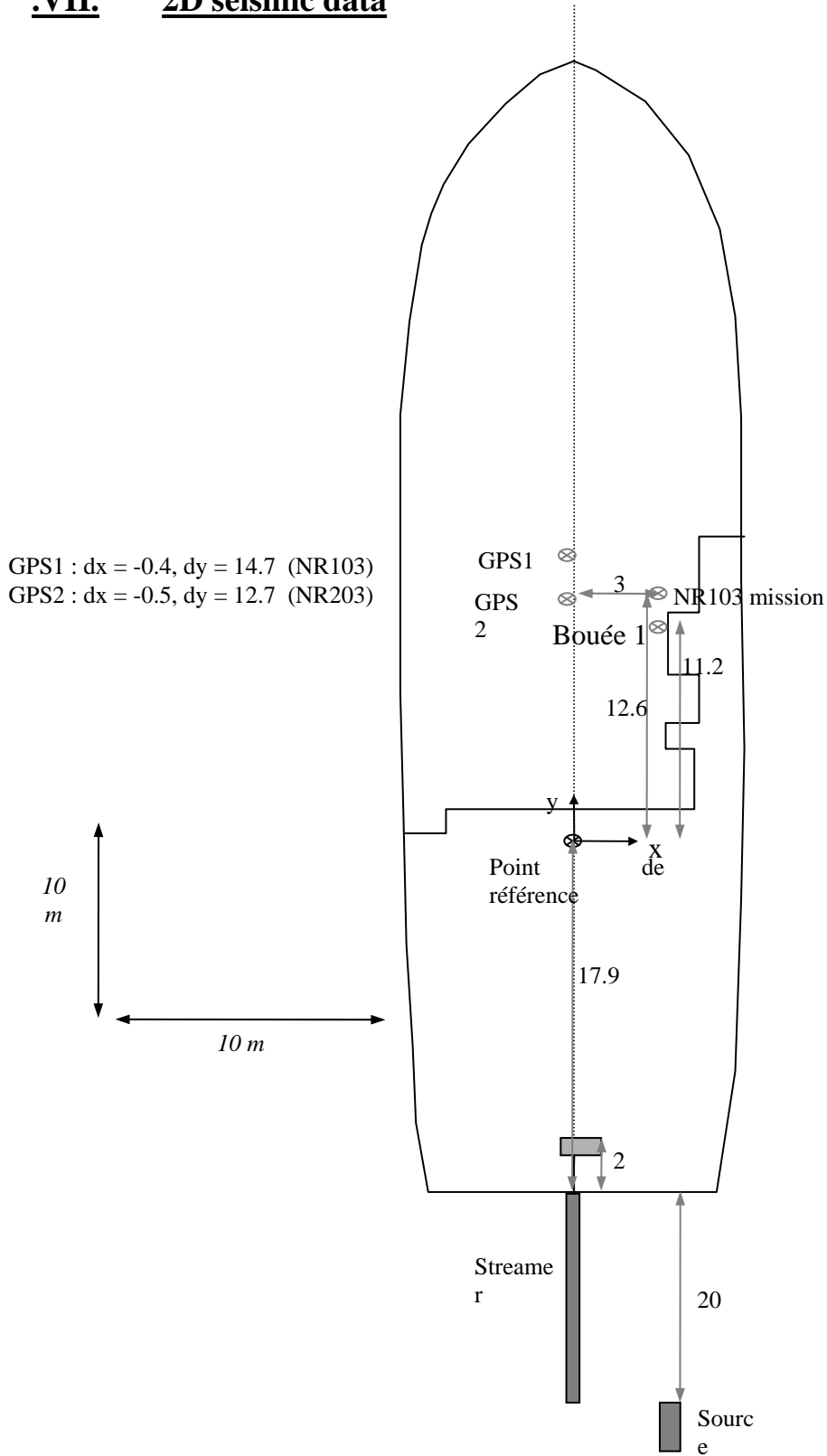

Figure 25: positions of the GPS antennas and streamers heads relative to the ship's reference point – 2D acquisition configuration

.VII.1. Streamer configuration

For the 2D acquisition, all the available (5) active sections were used to compose a streamer as long as possible:

SHS + RUM + ES + ALS + ALS + ALS + ALS + ALS + ES + Tail nylon string + buoy “fuse string” (3m)

Total length: 1001m

Active length : 750m

Streamer depth 3m except for line H2D24 (2m immersin)

Number of bird units : 6, except for lines H2D20->H2D24

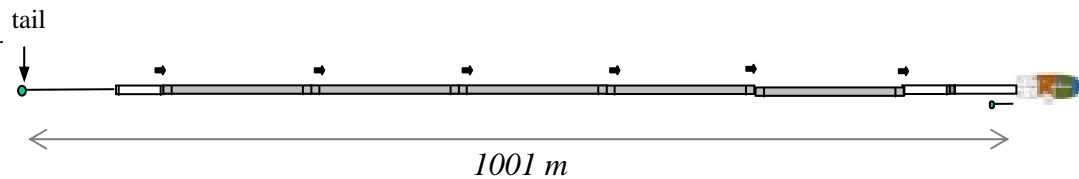

Figure 26: 2D seismic acquisition geometry

1 Streamer balancing (P=plastic ring, B=bronze ring)

Reference salinity: 34.59 psu

Reference temperature: 10.6°C

ALS : PPP B PPPP B PPPP B PPPP B PPPP

ES : B B

1 Birds offsets (from streamer's head)

Bird 1: 95.7m

Bird 2: 257.4m

Bird 3: 407.4m

Bird 4: 557.4m

Bird 5: 707.4m

Bird 6: 850.4m

.VII.2. Source configuration:

1 line, 3 mini-GI guns. Single shot mode (2 guns)

Variable shooting interval

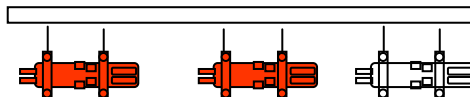

Figure 27: 2D source configuration

Recording settings:

Sampling frequency: 1000 Hz

Recording length: 3000 ms

Variable recording delay

Aux 1 = TB gun 1, Aux 2 = TB gun 2, Aux 3 = Water break

Recording format SEGD revision 2

Navigation buoys:

Buoy 2 = source

Buoy 3 = tail

.VII.3. Location Map

(Skyfix DGPS system)

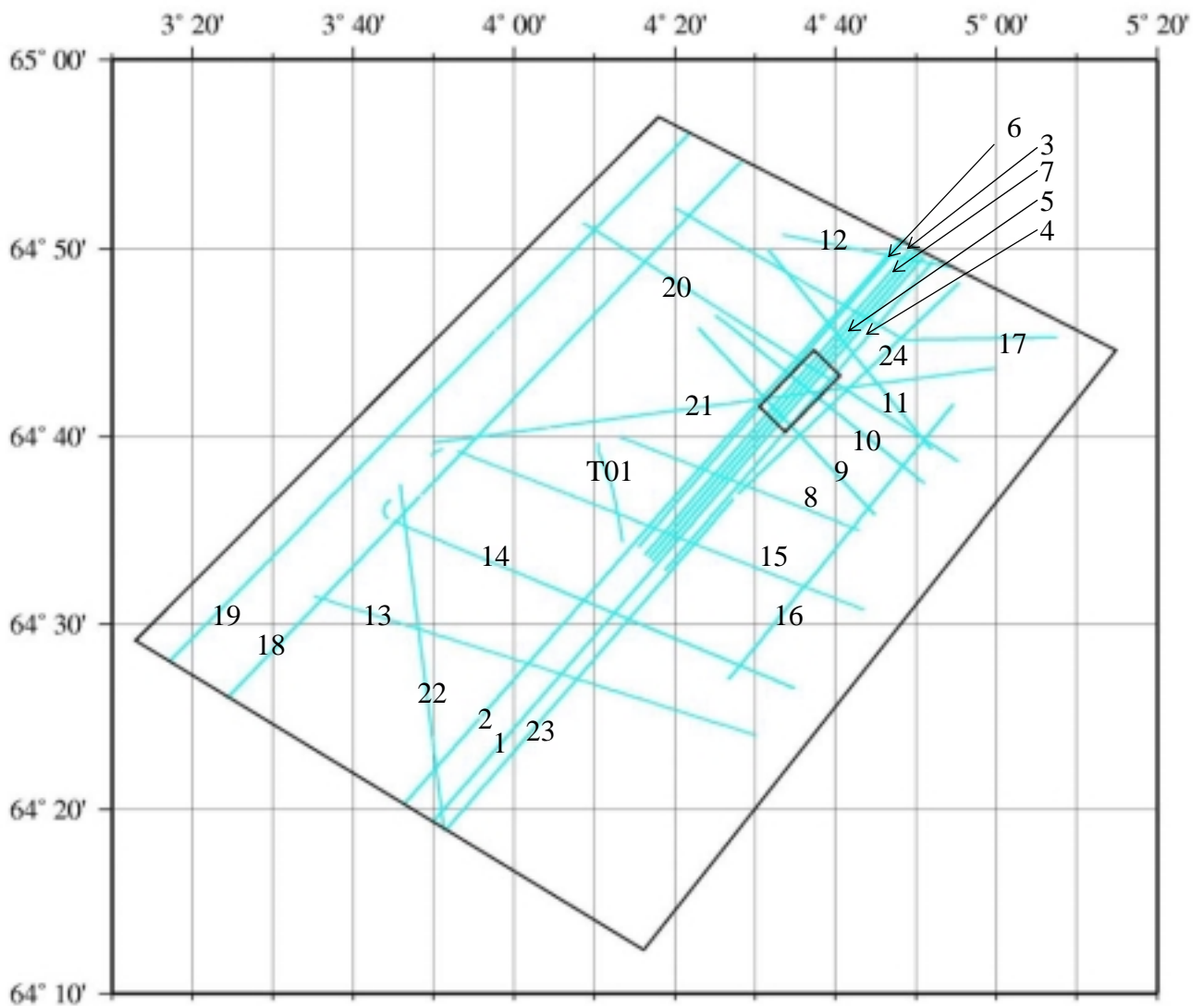

Figure 28: 2D seismic lines (acquisition speed 4.5 knots).

.VII.4. Onboard processing

On board processing was performed with Seismic Unix, in order to obtain migrated 2D stacks (see ANNEXE 1 for onboard processed seismic lines 1 to 24).

Processing sequence included

- Channel decimation (1 channel out of 2)
- SEGD to SEG-Y conversion
- Gun delay correction (20ms)
- Band pass filtering (15-20-240-260 Hz)
- Constant geometry application
- CDP sorting
- Velocity analysis
- Normal move out correction
- CDP stacking
- Constant velocity (1500m/s) migration
- ACG application (window length 300ms)

.VII.5. 2D seismic data example

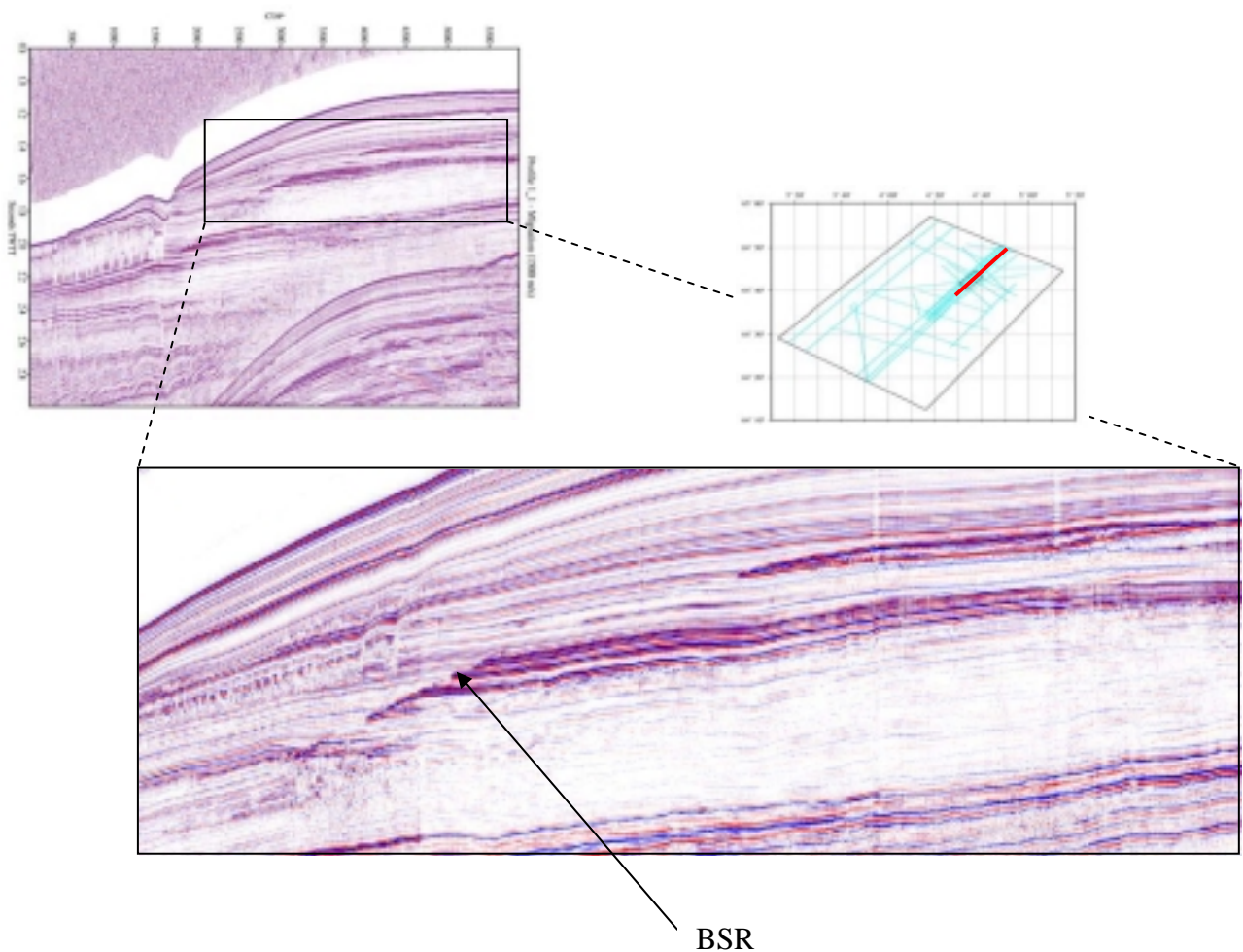

Figure 29: 2D seismic line 1, northern part

.VIII. Overview about data quality

Bathymetric data quality was good during the cruise, except for a few days when strong wind altered the data. These lines were acquired twice in order to ensure good data quality on the final maps.

In the shallower part of the area (northern part), there are some artifacts (the far beams values are overestimated) on the data that have to be corrected. The reason why such artifacts exist is not clear. It could be water velocities errors, but it has to be confirmed.

Chirp data was good during the whole cruise.

3D as well as 2D seismic data is partly noisy because 1/ the weather conditions were sometimes strong, and 2/ other seismic experiments involving industry seismic vessels (Ramform Vicking – Falcon Explorer) with powerful sources (7000-8000 I³) were conducted in the area during the cruise.

It is possible to remove most of the noise due to the other vessels (automatic detection and Tau-P filtering) without damaging the data (Figure 30).

As far as noise generated by the bad weather conditions is concerned, for the 3D box, the noisiest lines were shot again (about 20 lines). Furthermore, noise control based on averaging the noise in the water column can be performed and enables to edit the traces with too high a noise level. However, depending on how severe the acceptable noise threshold is, this trace edition can have a strong impact on the fold of the 3D box.

Acknowledgements :

We wish to thank Captain Thierry ALIX, officers and crew of N/O Le Suroit for their assistance.

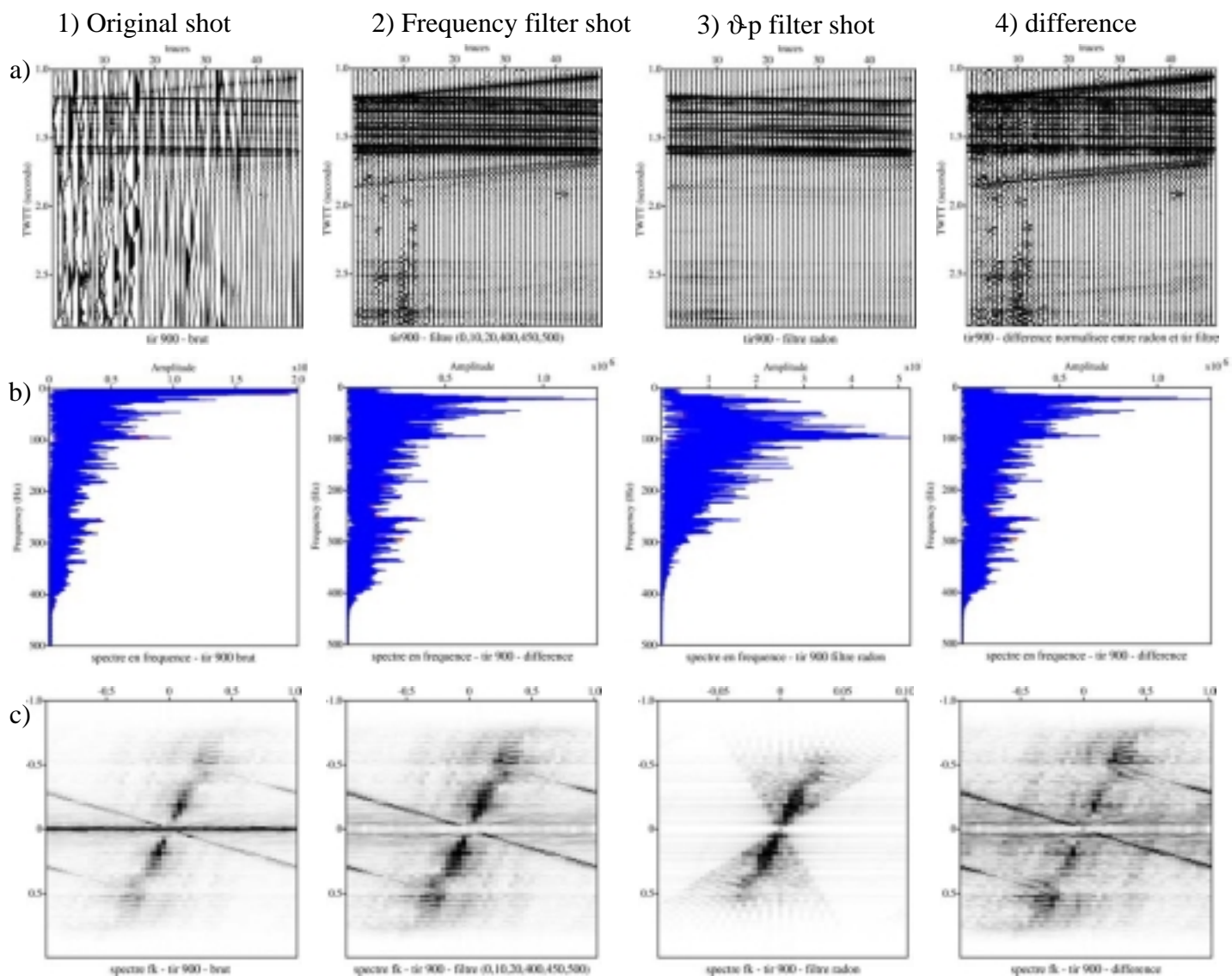

Figure 30 : Tau-P analysis. 1) Original noisy shot. 2) filter in the frequency domain, long wave length are removed, dipping noise comes from the Viking wessel. 3) filter in the Tau-P domain, dipping noise is removed. 4) difference between 2) and 3). a) time domain. b) frequency domain. c) F-K domain.

Figure index :

Figure 1 & Figure 2: general location map. Large box: multibeam survey. Small box: 3D seismic survey. Blue lines: 2D seismic lines..... 4

Figure 3: EM300 antennas on N/O Le Suroit 9

Figure 4: navigation map of the bathymetric survey. Blue line: navigation track. Red cross: sippican measurement 10

Figure 5: preliminary bathymetric map of the multibeam survey area. Note the slide scar feature, as well as the linear cliffs in the lower half of the map..... 11

Figure 6: preliminary reflectivity map of the multibeam survey area..... 12

Figure 7: CHIRP Transceivers on R/V LE Suroit..... 13

Figure 8: location map of the chirp lines..... 14

Figure 9: Chirp record, 14 July 2002, 10h04-10h14..... 19

Figure 10: Chirp record, 14 July 2002, 9h58-10h04 20

Figure 11: Chirp record, 27 June 2002, 9h12-9h57 21

Figure 12: synopsis of the seismic acquisition system on board N/O Le Suroit, showing the connections between the different elements of the HR system..... 22

Figure 13: Mini G-I GUN 23

Figure 14: positions of the GPS antennas and streamers heads relative to the ship’s reference point – 3D acquisition configuration..... 24

Figure 15: 3D acquisition geometry 25

Figure 16 : Bird unit 26

Figure 17 : Starboard streamer 26

Figure 18: 3D source configuration 26

Figure 19: 3D lines location map (acquisition speed 4.5 knots). 27

Figure 20: Example of the source and receivers positions calculated for a single shot..... 28

Figure 21: Final fold map with a 6.25x6.25m bin size 29

Figure 22: 3D shot data 30

Figure 23: 3D cube stacked data: inline line 121 31

Figure 24: Time slice of the 3D seismic box (1600ms). Note 1/ the “ BSR ” reflection crossing sedimentary reflections, 2/ the rounded structures (white arrows) probably related to fluid escapes. 32

Figure 25: positions of the GPS antennas and streamers heads relative to the ship’s reference point – 2D acquisition configuration..... 33

Figure 26: 2D seismic acquisition geometry 34

Figure 27: 2D source configuration 34

Figure 28: 2D seismic lines (acquisition speed 4.5 knots). 35

Figure 29: 2D seismic line 1, northern part..... 36

Figure 30 : Tau-P analysis. 1) Original noisy shot. 2) filter in the frequency domain, long wave length are removed, dipping noise comes from the Viking wessel. 3) filter in the Tau-P domain, dipping noise is removed. 4) difference between 2) and 3). a) time domain. b) frequency domain. c) F-K domain. 38